

## 50W LED light, use to -50 degree, Frozen Warehouse

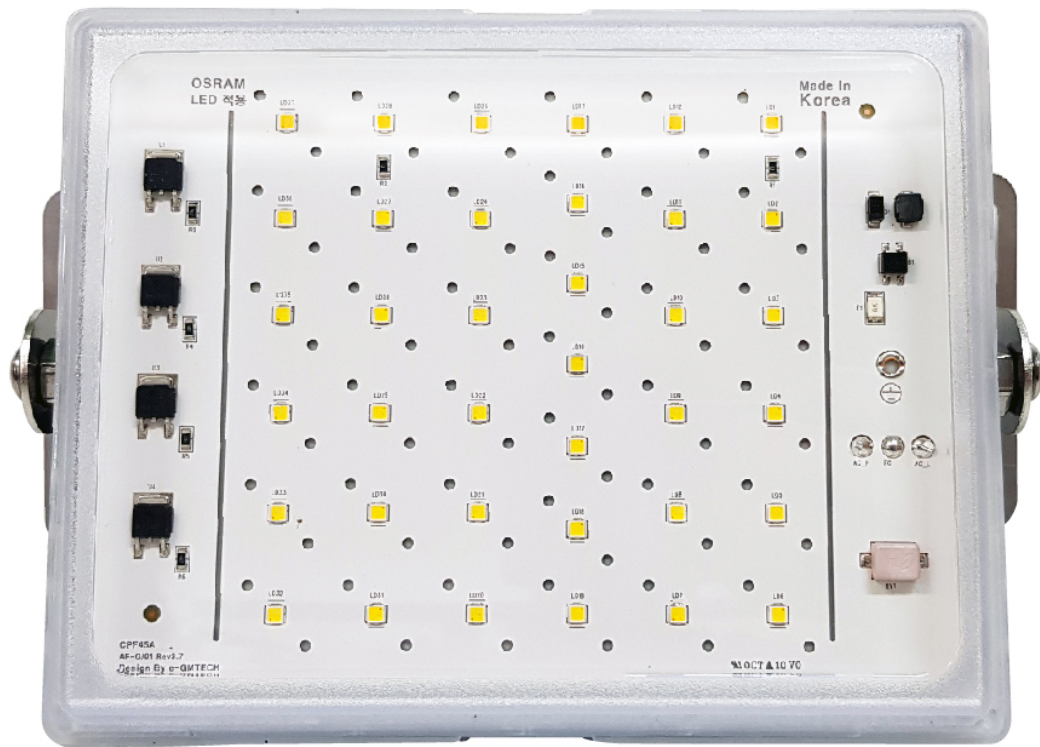





## Frozen Warehouse 50W

ORDER CODE : SF810

### SPECIFICATION

- 50W
- 220V(190V~290V) ,50~60Hz
- 3,686(lm)
- 1,300(lux)
- 75RA
- 6000K,3000K
- IP67
- 1kg
- 0.9 PF
- -50 ~40

### DIMENSION

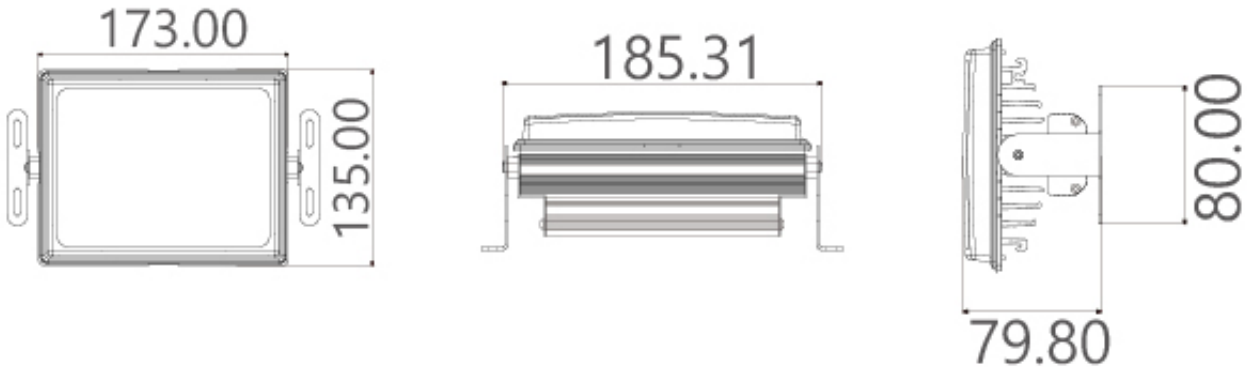

Tailored for Frozen Warehouse.

It is a product that can be used for a long time at -50 degrees.

1. World-class sealing (waterproof, moisture-proof) technology

- [Waterproof, moisture proof Technical description](#), IP68
- [US Patent](#), [Korean Patent 1](#), [Korean Patent 2](#)

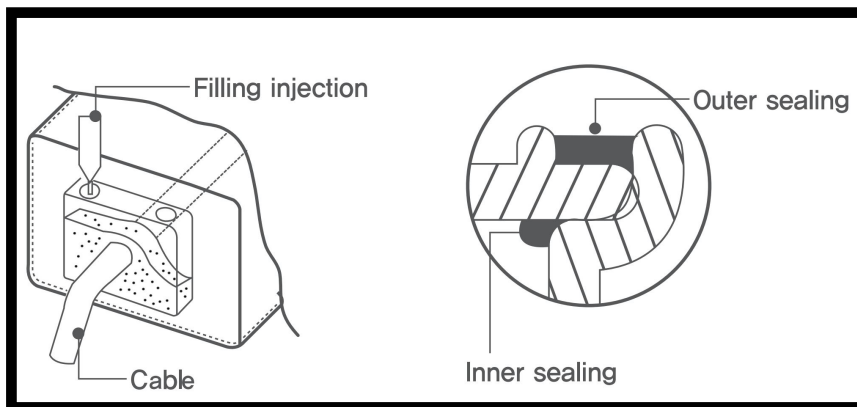

2. Used High quality aluminum (AL6063) extruded heat sink used

- Our original designed heat sink, Domestic processing

- Quality and heat dissipation efficiency are much higher than Chinese die casting method.

- It can be used in high humidity and high salinity coastal area because it does not rust almost

due to high quality AL6063 and film treatment.

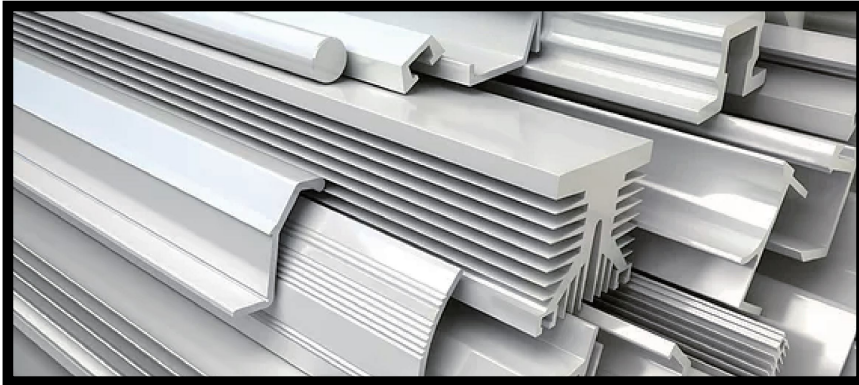

[ AL6063 Extrusion heat sink ]

### 3. Proven quality

- Freezer dedicated lighting Sale from 2015
- More than 5,000 products are sold each year.